

---

---

# MITSUBISHI SWING MACHINE PARTS CATALOG

Model { PB-810-10(PB-810)  
PB-820-10(PB-820)

## INDEX

1. 本体部分	Arm bed and its accessories	VOI-1
2. 上糸調節器部分	Upper thread tension regulator mechanism	VOI-3
3. 針棒, 天びん部分	Needle bar and take-up lever mechanism	VOI-5
4. 上軸, 縦軸部分	Upper shaft and vertical shaft mechanism	VOI-7
5. 縫目加減機構部分	Stitch regulator mechanism	VOI-9
6. 押え機構部分	Presser foot mechanism	VOI-11
7. 下軸, 上下送り軸部分	Rotating hook shaft and feed lifting rock shaft mechanism	VOI-13
8. カマ機構部分	Hook mechanism	VOI-15
9. 給油機構部分	Oil lubrication mechanism	VOI-19
10. ゲージ部品	Gauge parts	VOI-21
11. 付属品	Accessories	VOI-23



MITSUBISHI ELECTRIC CORPORATION

機構図 TOTAL ASSY.

MODEL : PB-810-10・820-10(PB-810・820)

PB-820-10

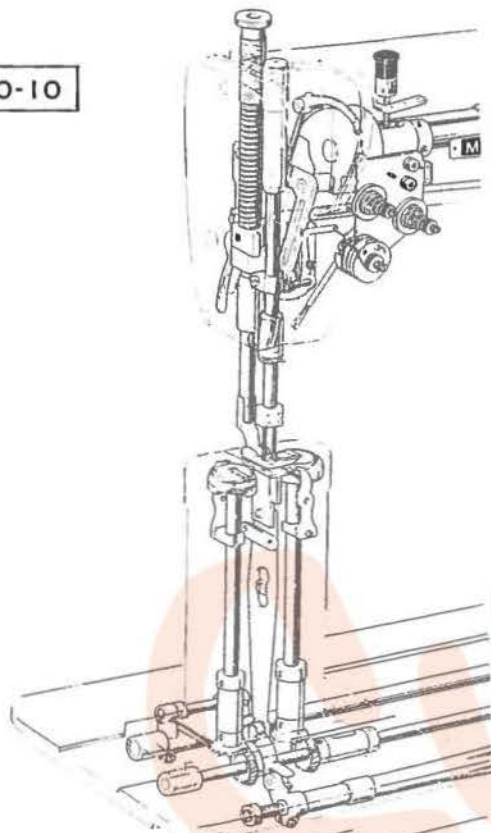

PB-810-10

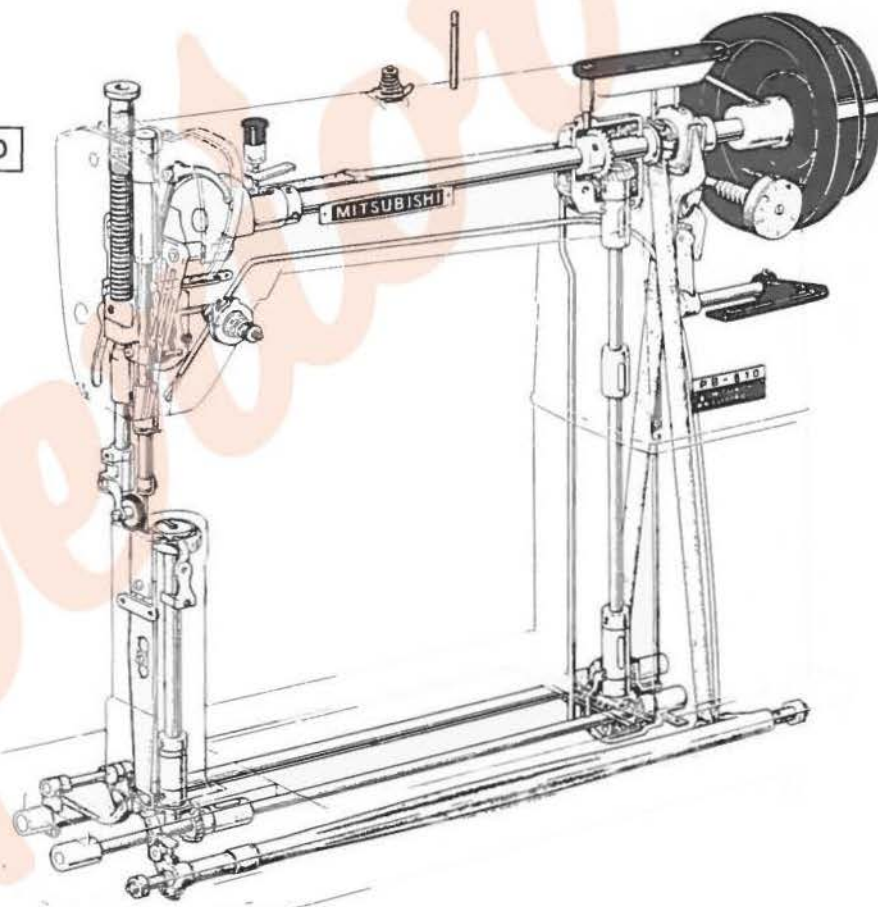

PB-810-10-820-10(PB-810-820)形 本体部分  
 ARM BED AND ITS ACCESSORIES

901

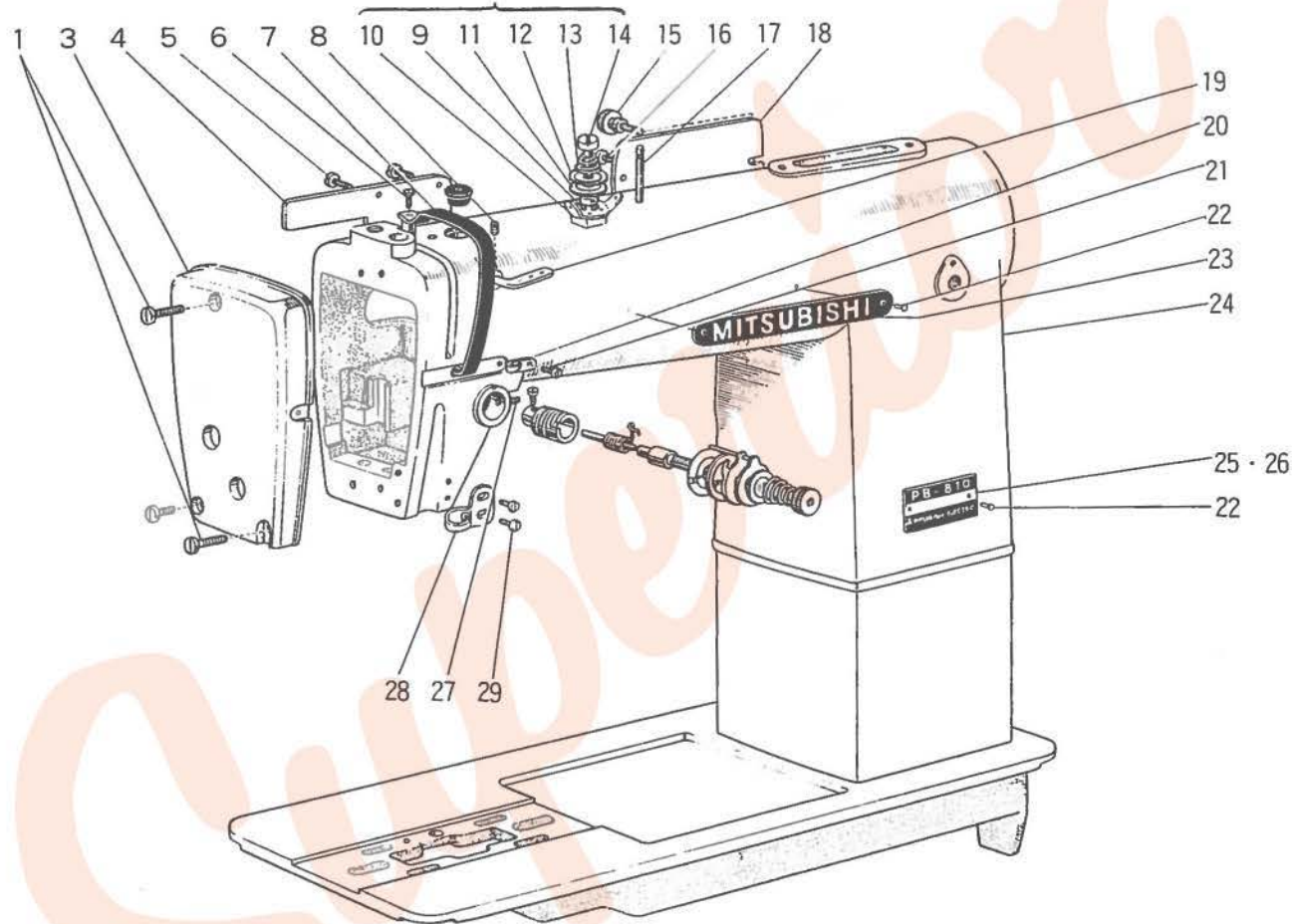

PB-810-10-820-10(PB-810-820)形 本体部分  
ARM BED AND ITS ACCESSORIES

Fig. No.	サービス部品コード Part No.	資材コード Code Nc.	部 品 名	Name of Part	個/台 Amt. req.		備 考 Remarks
					810	820	
1	M9 1101 004	W466810	ブラマイネジ 11/64(40)×9	Screw (for Fig. 3)	3	3	
3	MF 10A0 830	W321296	面 板	Face plate	1	1	
4	MF 60A0 326	W452217	カクシ板	Side cover	1	1	
5	M9 0915 003	W502952	丸平ネジ 9/64(40)×6	Screw (for Fig. 4)	2	2	
6	M9 1107 002	W500092	平ネジ 11/64(40)×5.5	Screw (for Fig. 7)	1	1	
7	MQ 50A0 584	W453559	天ビンカバー	Thread take-up cover	1	1	
8	M9 1108 001	B 503846	頭ナシ止メネジ 11/64(40)×5.5	Set screw (for Fig. 19)	1		
901	MF 20E0 550	W331471	プリテンション(組)	Pre-tension Assy,	1		
9	M9 0503 065	W462774	E型トメワ (3)	E type stop ring 3	1		
10	MF 40A0 181	W470269	イトアンナイ	Thread guide	1		
11	MF 20A0 476	W470268	スベーサ	Spacer	1		
12	MF 10A1 555	W501636	調子皿	Tension discs	2		
13	MV 01A0 245	W502479	糸調子バネ	Tension spring	1		
14	M9 1104 016	W470267	段付丸平ネジ 11/64(40)×16	Screw	1		
15	M9 0901 035	W464008	ツマミネジ 9/64(40)×14	Screw (for Fig. 18)	1	1	
16	M9 0908 015	W501371	段付ネジ 9/64(40)×7.2	Screw (for Fig. 18)	1	1	
17	MF 10A0 186	W461744	糸立棒	Spool pin	1	2	
18	MF 60A0 880	W447198	横ブタ	Arm side cover	1	1	
19	MF 10A0 180	B 409034	三ツ目糸カケ	3 hole thread retainer	1		
20	MV 01A0 181	W456517	糸カケ(アーム)	Thread guide (arm)	1	1	
21	M9 0904 011	W500147	丸皿ネジ 9/64(40)×6.5	Screw (for Fig. 20)	1	1	
22	M9 5001 062	W461746	ネジピョウ	Pin (for Fig. 23)	4	4	
23		W450620	社名板	Name Plate	1	1	
24		W110814	アームベット	Arm and bed	1	1	
25		W462894	形名板	Model plate	1		
26		W462895	形名板	Model plate		1	
27	M9 1508 001	B 509088	頭ナシ止メネジ 15/64(28)×7	Set screw (for Fig. 902)	1	1	
28	MQ 50A0 181	W464979	糸カケ(アーム下)	Thread guide (under arm)	1	1	
29	M9 1110 002	W500294	平ネジ 11/64(40)×8	Screw (for Fig. 28)	1	1	

PB-810-10·820-10(PB-810·820)形 上糸調節器部分  
 UPPER THREAD TENSION REGULATOR MECHANISM

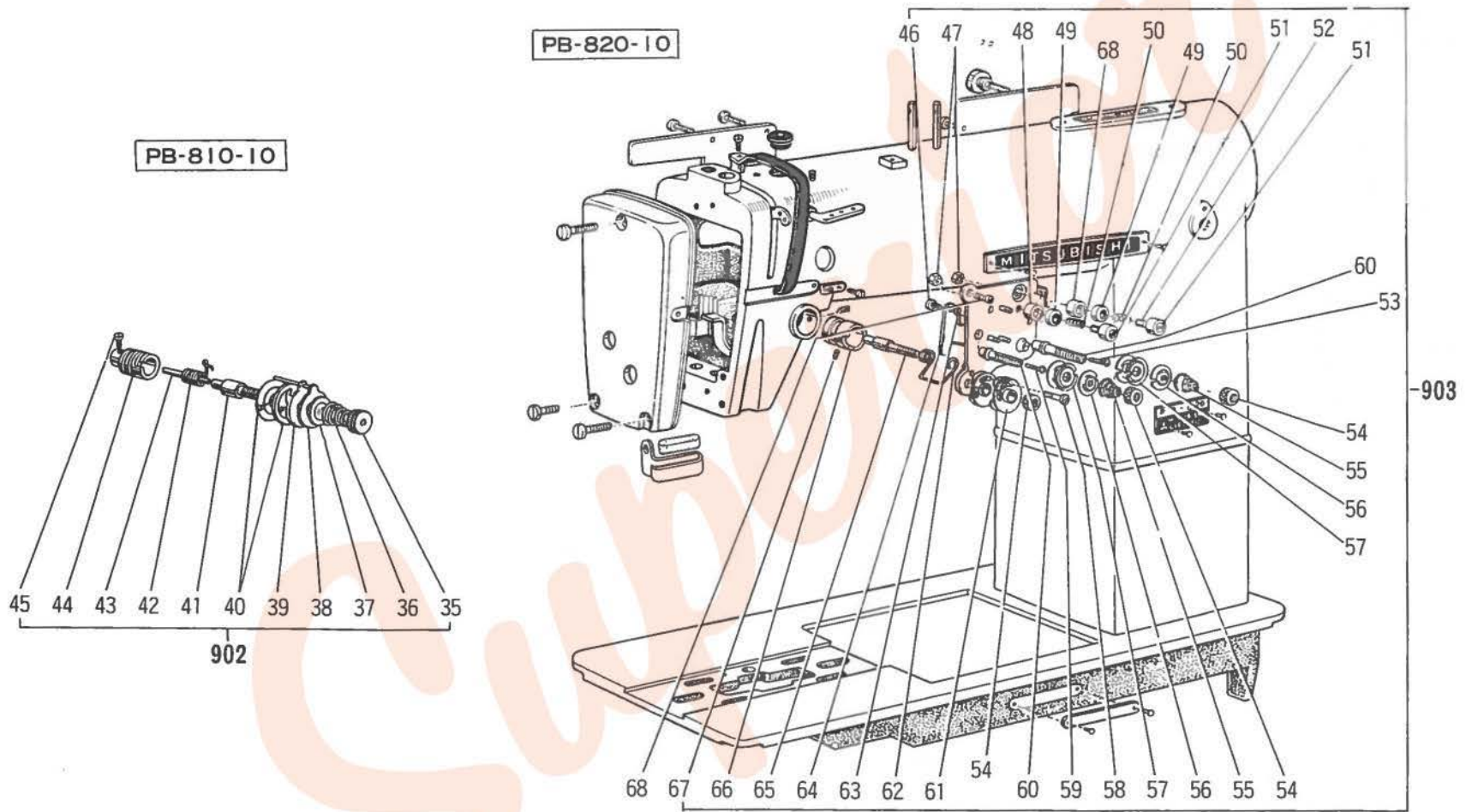

## PB-810-10・820-10(PB-810・820)形 上糸調節器部分

## UPPER THREAD TENSION REGULATOR MECHANISM

Fig. No.	サービス部品コード Part No.	資材コード Code No.	部 品 名	Name of Part	個/台 Amt. req.		備 考 Remarks
					810	820	
902	MV 01E0 210	W457599	上糸調節器 (組)	Thread tension regulator Assy,	1		
35	M9 1604 046	W501027	ツマミナット 1/4(40)	Thread tension regulating thumb nut	1		
36	MF 10A0 245	W450071	糸 調 子 バ ネ	Thread tension spring	1		
37	MF 10A0 556	B 419179	糸 調 子 皿 押 エ	Thread tension releasing disc	1		
38	MV 01A0 802	W458101	回 り 止 メ 板	Tension regulator stop plate	1		
39	MV 01A0 558	W458102	皿 受	Tension regulator bracket	1		
40	MF 10A0 555	W444059	調 子 皿	Tension disc	2		
41	MV 01A0 553	W458100	調 子 棒	Thread tension stud	1		
42	MV 01A0 187	W458104	糸 取 り バ ネ	Thread take-up spring	1		
43	M9 0212 060	W462787	ピ ン 2φ×35	Thread tension releasing pin	1		
44	MV 01A0 709	W458103	バネ止メブッシュ	Thread tension regulator bushing	1		
45	M9 0901 002	W500741	平 ネ ジ	Set screw (for Fig. 41)	1		
903	MV 02E0 210	W322775	上糸調節器 (組)	Thread tension regulator Assy,		1	
46	M9 0902 015	W501026	段 付 平 ネ ジ 9/64(40)×6	Tension releasing spring set screw		2	
47	M9 0901 045	W500307	ナ ッ ト 9/64(40)	Nut		2	
48	MN 10A0 155	W502213	糸 案 内 台	Thread guide bracket		2	
49	MN 10A1 555	W502212	糸 案 内 皿	Thread guide disc		2	
50	MN 10A1 572	W502065	上糸案内調子バネ	Thread tension spring		2	
51	MV 02A0 179	W502211	糸 案 内 フ タ	Controller cover		2	
52	M9 0902 016	W502210	段 付 丸 平 ネ ジ 9/64(40)×18	Thread tension releasing screw		2	
53	M9 0202 060	W502064-1	糸ユルメピン(小)	Tension releasing pin (small)		1	
54	M9 1003 046	W502940	調 子 ナ ッ ト	Thread tension regulating thumb nut		3	
55	MF 10A0 245	W450071	調 子 バ ネ	Thread tension spring		2	
56	MN 10A0 556	W445934	皿 オ サ エ	Tension regulator presser disc		2	
57	MN 10A0 555	W445933	調 子 皿	Tension disc		4	
58	M9 0603 003	W502062	丸 平 ネ ジ 3/32(56)×12	Thread controller disc screw		1	
59	M9 0203 060	W502064-2	糸ユルメピン(小) 2φ×15	Tension releasing pin (small)		1	
60	MN 10A0 553	W445932	調 子 棒	Tension stud		2	
61	MN 10E0 175	W462825	糸 案 内 車	Thread controller disc		2	
62	MN 10A0 187	W450012	糸 取 り バ ネ	Thread take-up spring		1	
63	MN 10A0 851	W502148	戻 シ バ ネ	Tension releasing spring		1	
64	MV 02A0 221	W457582	糸 ユ ル メ 板	Tension releasing plate		1	
65	MN 10A0 554	W450011	糸 調 子 軸	Tension stud		1	
66	MV 02A0 709	W457583	バネ止メブッシュ	Tension spring stop bushing		1	
67	M9 0902 001	W500187	頭ナシ止メネジ 9/64(40)×4.5	Screw		1	
68	M9 0919 003	W50093C	丸 平 ネ ジ 9/64(40)×14.5	Screw		1	

PB-810-10-820-10(PB-810-820)形 針棒, 天びん部分  
 NEEDLE BAR AND TAKE-UP LEVER MECHANISM

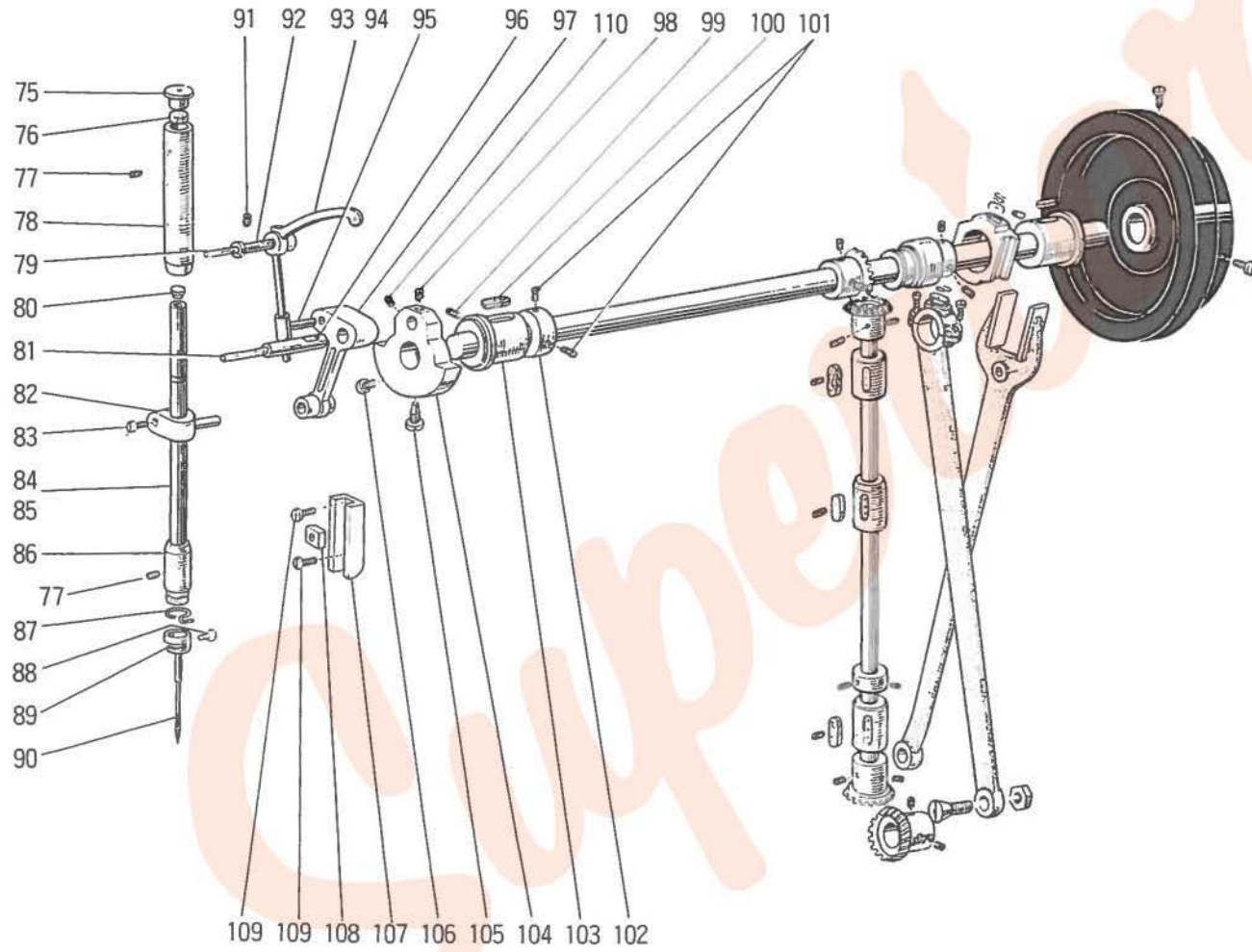

## PB-810-10-820-10(PB-810-820)形 針棒, 天びん部分

## NEEDLE BAR AND TAKE-UP LEVER MECHANISM

Fig. No.	Part No.	Code No.	部 品 名	Name of Part	個/台 Amt. req.		備 考 Remarks
					810	820	
75	MF 60A0 742	W502181H01	フ タ	Needle bar upper bushing cap	1	1	
76	MF 10A2 740	W500003H01	フェルト(針棒メタル上)	Needle bar upper bushing cap felt	1	1	
77	M9 1102 001	W500489	頭ナシ止メネジ 11/64(40)×2.7	Set screw (for Fig. 78)	2	2	
78	MF 60A0 663	W461760H01	針棒メタル (上)	Needle bar bushing (upper)	1	1	
79	MF 10E2 148	W469534H01	アブラヒモ 2.5φ×200	Oil wick	2	2	
80	MN 10A1 500	W502071	セ ン	Plastic plug (for Fig. 84, 85)	1	1	
81	MN 10A1 740	W500801	フェルト 6φ×32	Felt	1	1	
82	MF 10A0 665	W450054H01	針 棒 ダ キ	Needle bar connecting stud	1	1	
83	M9 0909 003	W501901	丸 平 ネ ジ 9/64(40)×6	Screw (for Fig. 82)	1	1	
84	MV 01A0 660	W454808	針 棒	Needle bar	1		
85	MV 02A0 660	W454842	針 棒	Needle bar		1	
86	MF 10A0 664	W450055	針棒メタル (下)	Needle bar bushing (under)	1	1	
87	MF 10A1 181	W502073	糸カケ(針棒メタル下)	Thread guide	1		
88	M9 0802 003	W502074	丸 平 ネ ジ 1/8(44)×4.5	Needle clamp screw	1		
89	MF 10A2 181	W502075	糸カケ (針棒)	Thread guide	1		
90		W499814	針		1	2	
91	M9 1516 001	W500006	頭ナシ止メネジ 15/64(28)×15	Set screw (for Fig. 92)	1	1	
92	MN 10A0 587	W445883H01	天ビン支エ軸	Take-up lever support stud	1	1	
93	MP 00B0 582	W462789	天 ビ ン	Take-up lever	1		
94	MV 02A0 582	W462903	天 ビ ン	Take-up lever		1	
95	MN 10A0 588	W445881H01	天ビン滑り	Take-up slide block	1	1	
96	MN 10A0 387	W445886H01	クランクピン	Crank pin	1	1	
97	MQ 50A0 661	W322778H01	針棒クランクロッド	Needle bar connecting crank rod	1	1	
98	M9 1601 001	W500486H01	頭ナシ止メネジ 1/4(40)×3	Set screw (for Fig. 104)	1	1	
99	M9 1513 001	B 509060	頭ナシ止メネジ 15/64(28)×11	Set screw (for Fig. 103)	3	3	
100	MF 60A2 740	W501524	フェルト	Felt	2	2	
101	M9 1606 001	B 504016	頭ナシ止メネジ 1/4(40)×6	Set screw (for Fig. 102)	2	2	
102	MF 20A0 352	W470214	カ ラ ー	Upper shaft collar	1	1	
103	MQ 50A0 232	W453556H01	上軸メタル (左)	Upper shaft bushing (left)	1	1	
104	MV 01A0 383	W453555H02	ク ラ ン ク	Crank	1	1	
105	M9 1802 006	B 503851	棒先平ネジ 9/32(28)×16	Set screw (for Fig. 104)	1	1	
106	M9 1801 002	W500306	平 ネ ジ 9/32(28)×13	Set screw (for Fig. 104)	1	1	
107	MF 10A0 662	W444056	針クガイド	Needle bar connecting link guide	1	1	
108	MF 10A0 325	W443934H01	角 駒	Square block (for Fig. 82)	1	1	
109	M9 1110 002	W500294	平 ネ ジ 11/64(40)×8	Screw ( for Fig. 107)	2	2	
110	M9 1606 001	B 504016H01	頭ナシ止メネジ 1/4(40)×6	Screw (for Fig.104)	1	1	



PB-810-10-820-10(PB-810-820)形 上軸, 豎軸部分

UPPER SHAFT AND VERTICAL SHAFT MECHANISM

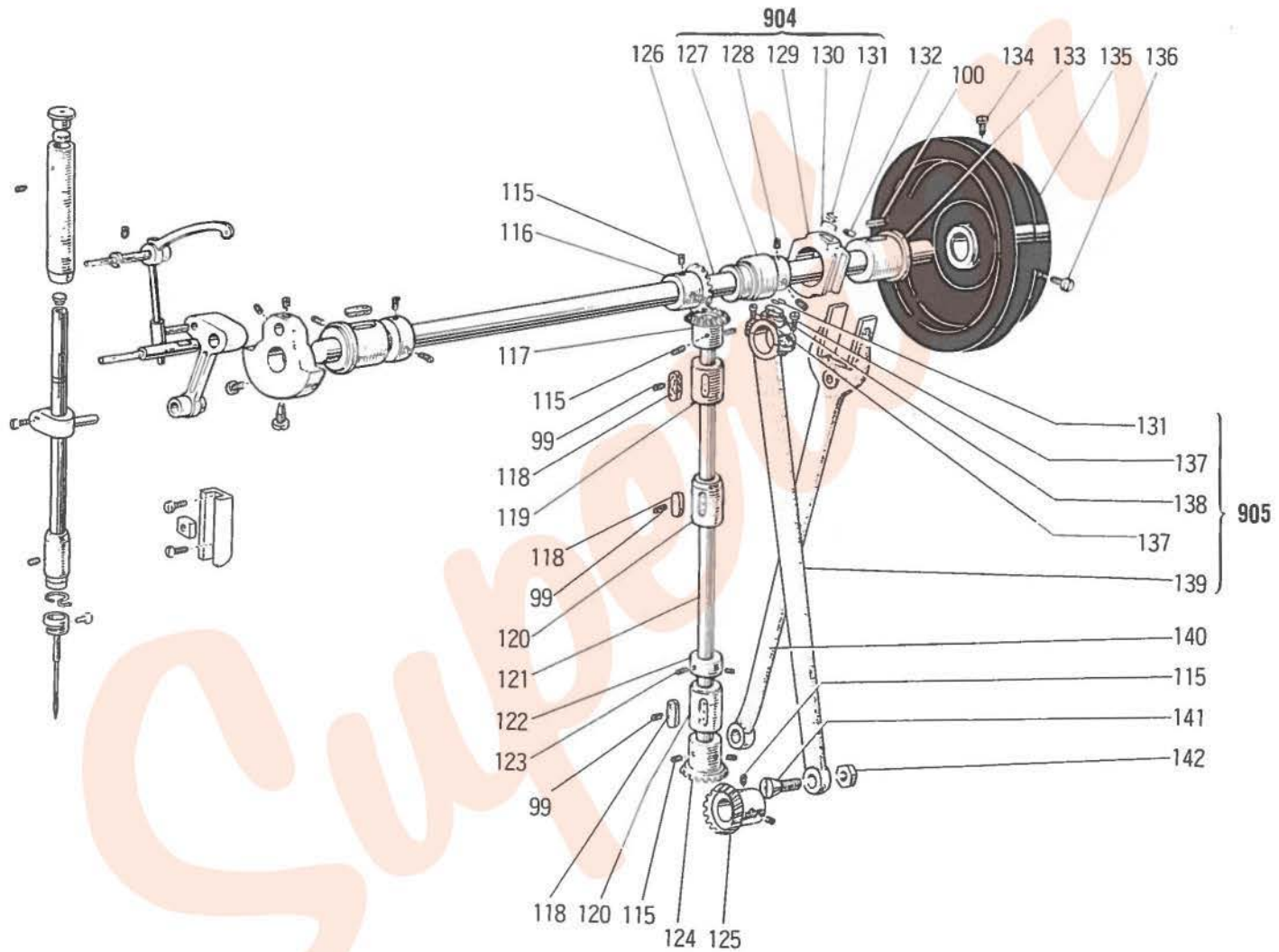

## PB-810-10-820-10(PB-810-82C)形 上軸, 豎軸部分

## UPPER SHAFT AND VERTICAL SHAFT MECHANISM

Fig. No.	サービス部品コード Part No.	資材コード Code No.	部 品 名	Name of Part	個/台 Amt. req.		備 考 Remarks
					810	820	
115	M9 1606 001	B 504016	頭ナシ止メネジ 1/4(40)×6	Set screw (for Fig. 116)	6	6	
116	MV 01A0 331	W444106	傘歯車 (上軸)	Bevel gear (upper shaft)	1	1	
117	MF 10A0 333	W444107	傘歯車 (豎上)	Bevel gear (vertical shaft upper)	1	1	
118	MF 60A3 740	W500956	フェルト	Felt	3	3	
119	MQ 70A0 521	W462791	豎軸メタル (上)	Vertical shaft bushing (upper)	1	1	
120	MF 67B0 522	W462734	豎軸メタル (下)	Vertical shaft bushing (upper)	2	2	
121	MQ 70A0 520	W452369	豎 軸	Vertical shaft	1	1	
122	MF 10A0 352	B 422844HJ1	カ ラ ー	Vertical shaft collar	1	1	
123	M9 1508 001	B 509088	頭ナシ止メネジ 15/64(28)×8	Set screw (for Fig. 122)	2	2	
124	MF 10A0 334	W444109	傘歯車 (豎下)	Bevel gear (vertical shaft under)	1	1	
125	MF 10A0 332	W444111	傘歯車 (下軸)	Bevel gear (hook shaft)	1	1	
126	MV 01A0 230	W322709	上 軸	Upper shaft	1	1	
904	MV 01E0 280	W462790	送りカム (組)	Feed cam Assy,	1	1	
127		W452225	送 リ カ ム	Feed cam	1	1	
128	M9 1508 001	B 509088	頭ナシ止メネジ 15/64(28)×8	Set screw (for Fig. 127)	2	2	
129		B 409336	カ ム ス ベ リ	Feed cam ring	1	1	
130	MF 60A1 740	W500738	フ ェ ル ト	Felt	2	2	
131	MF 60A0 700	W500836	バ ネ	Spring (for Fig. 130)	2	2	
132	M9 1516 001	W500006	頭ナシ止メネジ 15/64(28)×15	Set screw (for Fig. 133)	1	1	
133	MF 60A0 233	W451575	上軸メタル (右)	Upper shaft bushing (right)	1	1	
134	M9 1502 002	W500509	平 ネ ジ 15/64(28)×12	Set screw (for Fig. 135)	2	2	
135	MF 65B0 682	W322737	ハ ズ ミ 車	Balance wheel	1	1	
136	M9 2201 003	W461726	丸 平 ネ ジ 11/32(28)×10	Screw (for Fig. 135)	1	1	
905	MV 01E0 384		クランクロッド(組)	Crank rod Assy,	1	1	
137	M9 1203 002	B 509178	平 ネ ジ 3/16(28)×15	Screw (for Fig. 139)	2	2	
138	MG 30B0 740	W464014	フ ェ ル ト	Felt	1	1	
139		W322035	クランクロッド	Crank rod	1	1	
140	MV 01A0 744	W322024	フ タ 又	Feed forked connection	1	1	
141	M9 1803 036	B 508959	テーパ-頭ネジ 9/32(28)×23	Crank rod taper screw (for Fig. 139)	1	1	
142	M9 1802 045	B 508961	ナ ッ ト	Nut (for Fig. 141)	1	1	

PB-810-10-820-10(PB-810-820)形 縫目加減機構部分  
 STITCH REGULATOR MECHANISM

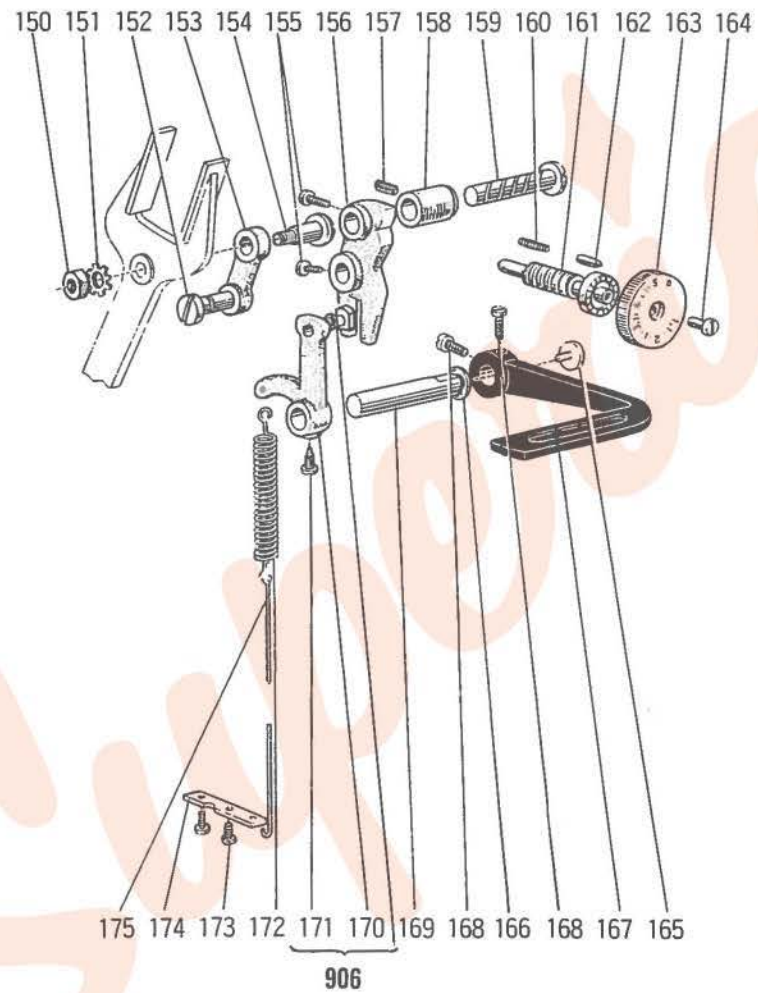

PB-810-10-820-10(PB-810-820)形 縫目加減機構部分  
STITCH REGULATOR MECHANISM

Fig. No.	サービス部品コード Part No.	資材コード Code No.	部 品 名	Name of Part	個/台 Amt. req.		備 考 Remarks
					810	820	
150	M9 1802 045	B 508961HC1	ナ ッ ト 9/32(28)	Nut (for Fig. 154)	1	1	
151	M9 0801 051	W461797	歯 付 座 金 B8S	Lock washer (for Fig. 150)	1	1	
152	M9 0905 063	W501377H01	平 ビ ン 9φ×27	Set pin (for Fig. 153)	1	1	
153	MF 10A0 153	W447215	案内テコツナギ	Feed connecting link	1	1	
154	M9 1807 015	W501406	段 付 平 ネ ジ 9/32(28)×23.3	Screw (for Fig. 153)	1	1	
155	M9 1504 002	B 508963	平 ネ ジ 15/64(28)×10	Set screw (for Fig. 156)	2	2	
156	MV 01A0 152	W452298	案 内 テ コ	Feed regulator	1	1	
157	M9 1513 001	B 509060	頭ナシ止メネジ 15/64(28)×10	Set screw (for Fig. 158)	3	3	
158	MF 10A0 750	W502090	ブ ッ シ ュ	Feed regulator bushing	1	1	
159	M9 0902 063	W456514	段 付 ビ ン 9φ×44	Set pin (for Fig. 156)	1	1	
160	MF 10A2 572	B 509164	押 シ バ ネ	Spring (for Fig. 162)	1	1	
161	MV 01A0 640	W452299	ネ ジ 棒	Screw-bar	1	1	
162	MF 10A0 852	B 419163	戻 リ 止 メ	Stopper pin (for Fig. 163)	1	1	
163	MF 11D0 631	W331486	ダ イ ヤ ル	Stitch length regulator dial	1	1	
164	M9 1209 002	B 503887	平 ネ ジ 3/16(28)×8	Screw (for Fig. 163)	1	1	
165	M9 1207 003	B 509288	丸 平 ネ ジ 3/16(28)×6.5	Screw (for Fig. 167)	1	1	
166	M9 1003 653	B 503895	バ ネ 座 金	Spring washer (for Fig. 167)	1	1	
167	MF 10A0 632	W453509	縫目加減取手	Reverse sewing lever	1	1	
168	M9 1501 002	W502945	平 ネ ジ 15/64(28)×8.5	Set screw (for Fig. 167)	2	2	
169	MF 60A0 633	W462608	縫目加減軸	Shaft (for Fig. 167)	1	1	
906	MF 10E0 635	W462614	縫目加減腕 (組)	Reverse sewing crank Assy,	1	1	
170	MF 60A0 634	W447217H01	縫目加減腕	Reverse sewing crank	1	1	
171	M9 1501 007	B 509256	棒先丸平ネジ 15/64(28)×14.5	Set screw (for Fig. 170)	1	1	
172	MF 60A0 572	W445312	ツル巻バネ	Spring (for Fig. 170)	1	1	
173	M9 1110 002	W500294	平 ネ ジ 11/64(40)×8	Screw (for Fig. 174)	2	2	
174	MV 01A0 708	W445315	バネ止メ板	Bracket (for Fig. 172)	1	1	
175	MV 01A0 738	W452226	引 棒	Knee lifter rod	1	1	

PB-810-10-820-10(PB-810-820)形 押え機構部分  
PRESSER FOOT MECHANISM

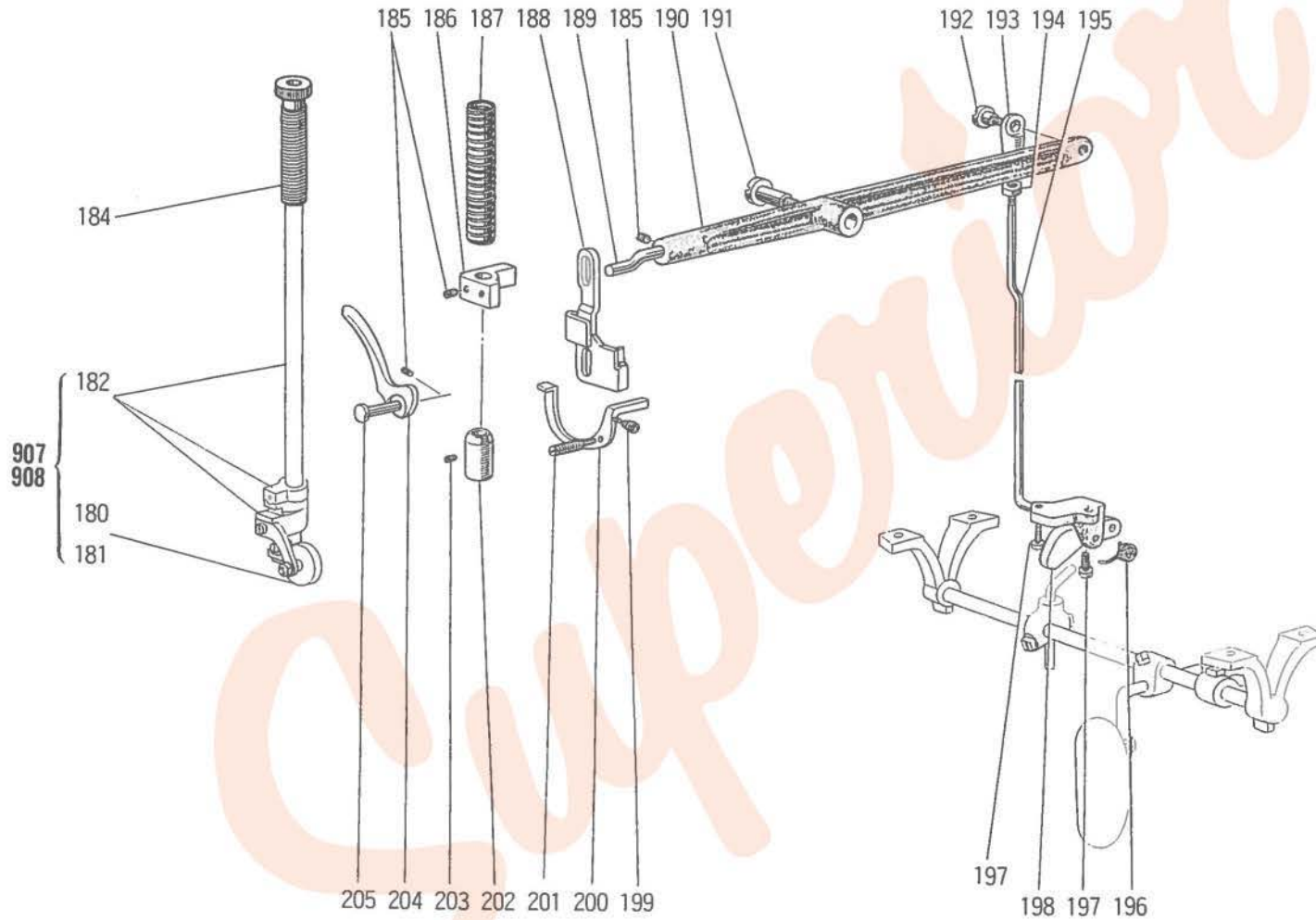

PB-810-10-820-10(PB-810-820)形 押え機構部分  
PRESSER FOOT MECHANISM

Fig. No.	サービス部品コード Part No.	資材コード Code No.	部 品 名	Name of Part	個/台 Amt. req.		備 考 Remarks
					810	820	
907	MV 01E0 974	W456513	ローラー押エ棒(組)	Roller presser bar Assy,	1		
908	MV 02E0 974	W326206	ローラー押エ棒(組)	Roller presser bar Assy,		1	
180	MV 01E0 973	W456530	ローラー押エ(組)	Roller presser Assy,	1		
181	MV 02E0 973	W457577	ローラー押エ(組)	Roller presser Assy,		1	
182	MV 01A0 262	W456526	押 エ 棒	Presser bar Assy,	1		
184	M9 3201 035	B 409037	押エ調節ネジ 1/2(28)×43	Presser releasing thumb screw	1	1	
185	M9 1508 001	B 509088	頭ナシ止メネジ 15/64(28)×7	Set screw (for Fig. 182, 183)	3	3	
186	MF 20A0 265	W467222	押エ棒ダキ	Presser bar holder	1	1	
187	MV 01A0 259	W461782	押 エ バ ネ	Presser spring	1	1	
188	MV 01A0 510	W472525	ソウサイタ	Knee lifter lever link	1	1	
189	M9 0505 063	W464038	引上ゲピン	Knee lifter lever pin	1	1	
190	MF 60A0 725	B 309199	ヒザ上ゲテコ	Knee lifter lever	1	1	
191	M9 1551 016	B 503843	段付丸平ネジ 15/64(24)×30	Knee lifter lifting lever hinge screw	1	1	
192	M9 1505 016	B 509176	段付丸平ネジ 15/64(28)×10	Screw (for Fig. 193)	1	1	
193	MF 40A0 591	W462748	テコ接手	Knee lifter lever joint	1	1	
194	M9 1251 045	B 509177	ナ ッ ト 3/16(32)	Nut (for Fig. 195)	1	1	
195	MV 01A0 593	W452219	テコ引き棒	Knee lifter lever connection rod	1	1	
196	MF 60A0 729	W444040	ヒネリバネ	Spring (for Fig. 198)	1	1	
197	M9 1104 003	B 509264	丸平ネジ 11/64(40)×12	Screw (for Fig. 198)	2	2	
198	MF 60A0 594	B 419209	テコ引き仕掛	Knee lifter lever connecting rod finger	1	1	
199	MF 10A2 245	B 409092	円錐バネ	spring (for Fig. 200)	1	1	
200	MV 01A0 220	W472529	糸ユルメ	Tension releasing lever	1	1	
201	M9 1102 033	W502123	ピンネジ 11/64(40)×23.5	Set screw (for Fig. 200)	1	1	
202	MF 10A0 267	W502081	押エ棒メタル	Presser bar bushing	1	1	
203	M9 1102 001	W500489	頭ナシ止メネジ 11/64(40)×2.7	Set screw (for Fig. 202)	1	1	
204	MF 60A0 252	W443698	押エ上げ	Presser bar lifter	1	1	
205	M9 0704 063	B 503977	押エ上ゲピン 7φ×19	Presser bar lifter pin	1	1	

PB-810-10·820-10(PB-810·820)形 下軸, 上下送り軸部分

ROTATING HOOK SHAFT AND FEED LIFTING ROCK SHAFT MECHANISM

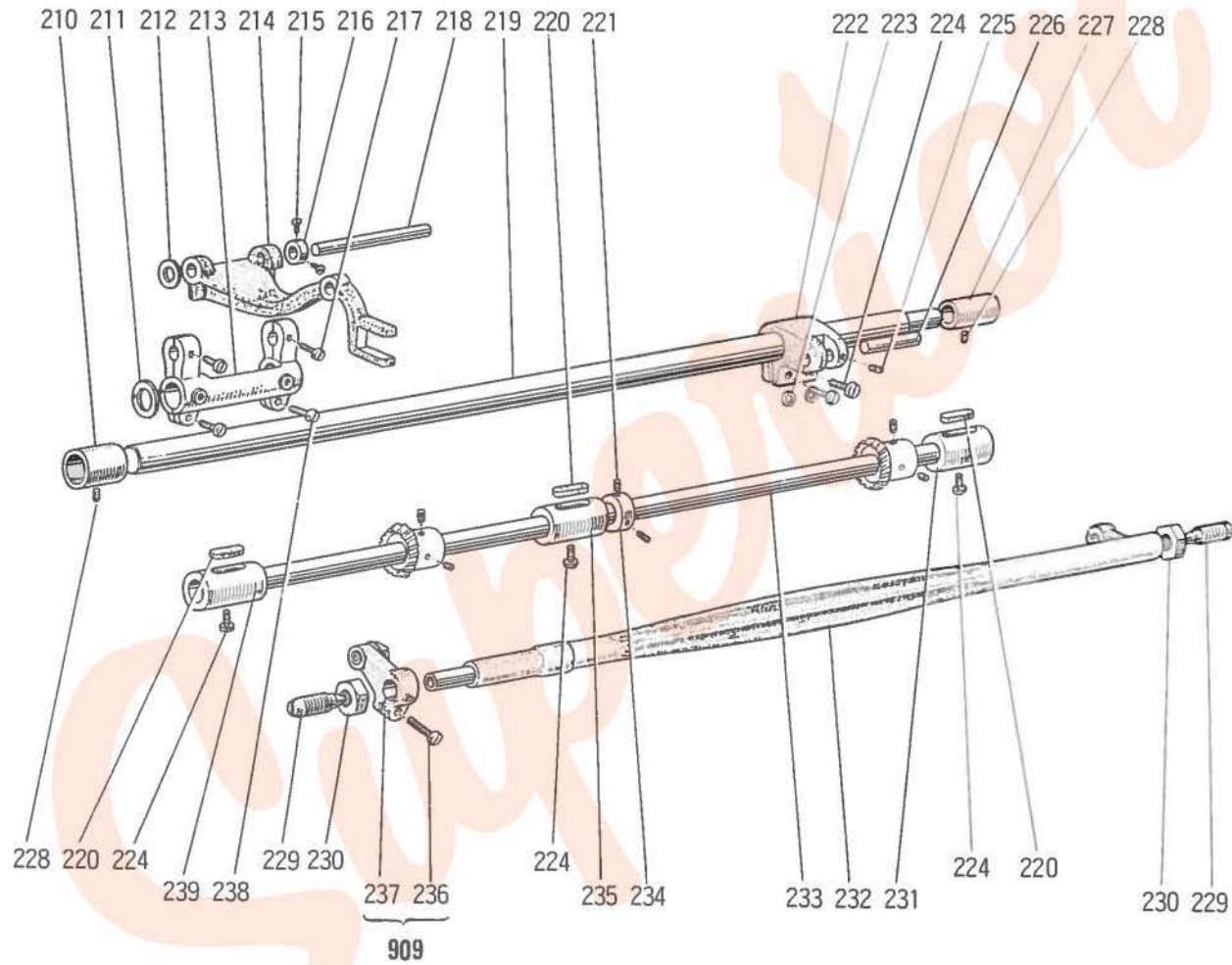

## PB-810-10-820-10(PB-810-820) 下軸, 上下送り軸部分

## ROTATING HOOK SHAFT AND FEED LIFTING ROCK SHAFT MECHANISM

Fig. No.	サービス部品コード Part No.	資材コード Code No.	部 品 名	Name of Part	個/台 Amt. rep.		備 考 Remarks
					810	820	
210	MF 10A0 286	W454875	送り軸メタル	Feed rock shaft bushing (left)	1	1	
211	M9 3001 052	W502467	座 金 15φ	Slide washer (for Fig. 213)	1	1	
212	M9 0606 050	W502480	座 金 6.3φ	Washer (for Fig. 214)	1	1	
213	MV 01A0 278	W462893	送り腕 (水平左)	Feed rock shaft crank (left)	1	1	
214	MV 01A0 281	W452246	送り台	Feed bar	1	1	
215	M9 0901 002	W500741	平 ネ ジ 9/64(40)×4	Set screw (for Fig. 216)	2	2	
216	MF 10A2 352	W501442	カ ラ ー	Collar (for Fig. 214)	1	1	
217	M9 1110 002	W500294	平 ネ ジ 11/64(40)×8	Set screw (for Fig. 218)	2	2	
218	MF 10A0 283	W501447	送り台支エ軸	Feed bar shaft	1	1	
219	MF 65B0 491	W454811	水平送り軸	Feed rock shaft	1	1	
220	MF 60A3 740	W500956	フェルト	Felt	3	3	
221	M9 1503 001	B 508971	頭ナシ止メネジ 15/64(28)×4.5	Set screw (for Fig. 234)	2	2	
222	MF 10A0 279	W447172	送り腕 (水平右)	Feed rock shaft crank (right)	1	1	
223	M9 0402 050	W461040	座 金 4.5φ	Washer (for Fig. 224)	2	2	
224	M9 1113 002	W500182	平 ネ ジ 11/64(40)×15	Screw (for Fig. 222)	5	5	
225	M9 1108 001	B 503846	頭ナシ止メネジ 11/64(40)×5.5	Set screw (for Fig. 226)	1	1	
226	M9 0901 060	W501107HC1	ピン (送り腕用) 9.5φ×25	Feed rock shaft bushing (right)	1	1	
227	MF 10A0 287	W446173	送り軸メタル	Set screw (for Fig. 227)	1	1	
228	M9 1513 001	B 509060	頭ナシ止メネジ 15/64(28)×10	Screw (for Fig. 232)	2	2	
229	M9 2403 034	W464015	センターネジ 3/8(28)×35	Set pin (for feed rock crank rod)	2	2	
230	M9 2402 045	B 509118	ナ ッ ト 3/8(28)	Nut (for Fig. 229)	2	2	
231	MV 01A0 452	W462738	下軸メタル (右)	Rotating hook shaft bushing (right)	1	1	
232	MV 01A0 460	W320450	上下送り軸	Feed lifting rock shaft	1	1	
233	MQ 70A0 450	W454833	下 軸	Rotating hook shaft	1	1	
234	MF 10A0 352	B 422844	カ ラ ー	Collar (for Fig. 233)	1	1	
235	MQ 70A0 452	W462736	下軸メタル (中)	Rotating hook shaft bushing (middle)	1	1	
909	MF 60E0 276	W462749	送り腕(上下左)(組)	Feed lifting rock shaft crank (left) Assy,	1	1	
236	M9 1113 002	W500182	平 ネ ジ 11/64(40)×15	Screw (for Fig. 237)	1	1	
237	MG 30B0 276	W462642	送り腕 (上下左)	Feed lifting rock shaft crank (left)	1	1	
238	M9 1112 002	W501889	平 ネ ジ 11/64(40)×12	Screw (for Fig. 213)	2	2	
239	MF 67B0 451	W462735	下軸メタル (左)	Rotating hook shaft bushing (left)	1	1	



PB-810-10・820-10(PB-810・820)形 カマ機構部分  
 HOOK MECHANISM

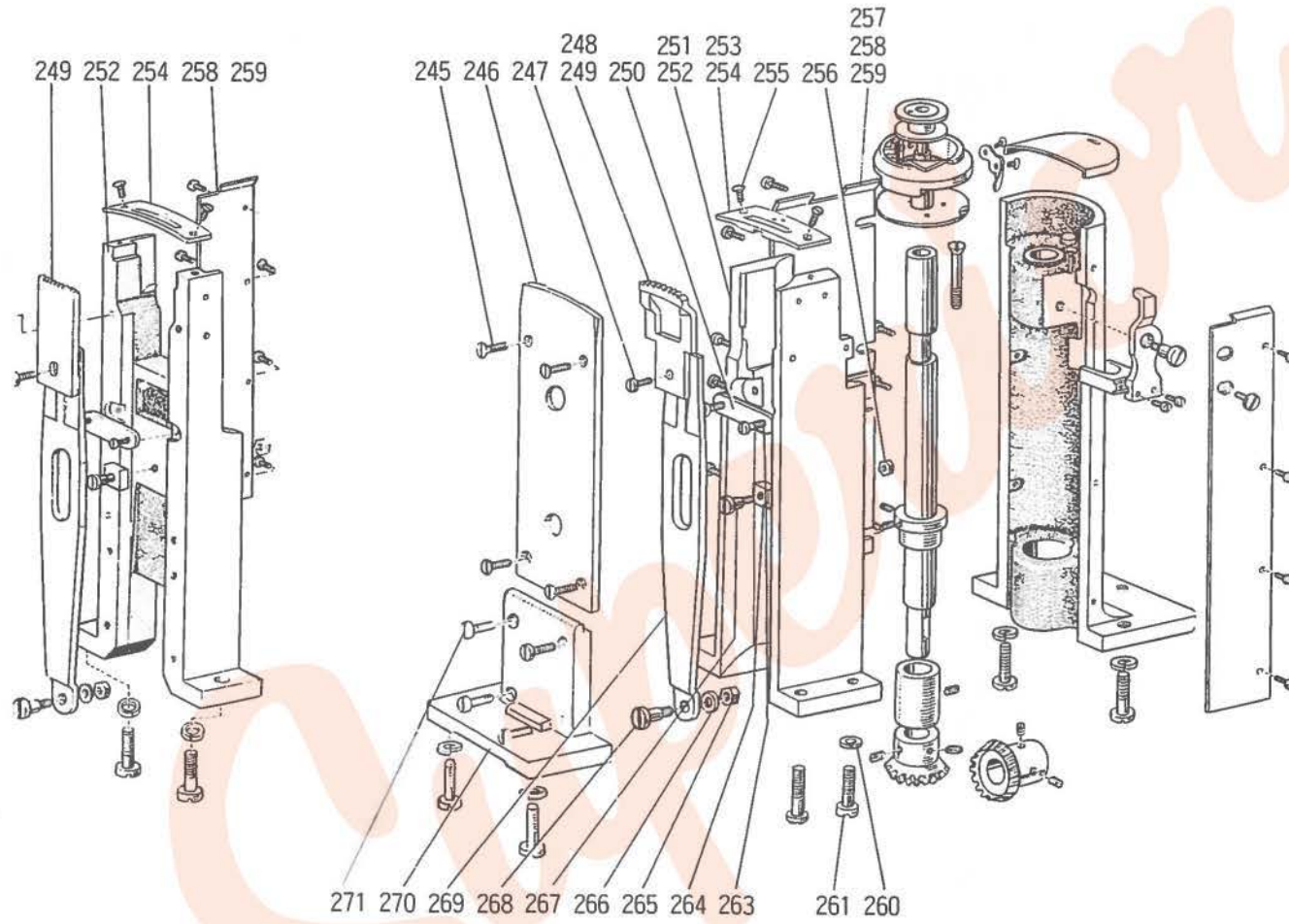

PB-810-10-820-10(PB-810-820)形 カマ機構部分  
HOOK MECHANISM

Fig. No.	サービス部品コード Part No.	資材コード Code No.	部 品 名	Name of Part	個/台 Amt. req.		備 考 Remarks
					810	820	
245	M9 1110 002	W500294	平 ネ ジ 11/64(40)×8	Screw (for Fig. 246)	4		
246	MV 01A0 339	W452253	後 カ バ ー	Rear cover plate	1		
247	M9 1107 002	W500092	平 ネ ジ 11/64(40)×5.5	Screw (for Fig. 248, 249)	1	1	
248	MV 01A0 104	W456512	送 り	Feed dog	1		
249	MV 02J0 104	W457581	送 り (1/16)	Feed dog (1/16)		1	
250	MV 01A0 429	W502315	支 エ 板	Supporter plate	1	1	
251	MQ 70A0 603	W220170	送 り 板 取 付 台	Feed plate set bracket	1		
252	MV 02A0 603	W220610	送 り 板 取 付 台	Feed plate set bracket		1	
253	MV 01A0 101	W456511	針 板	Needle plate	1		
254	MV 02J2 101	W457580	針 板 (1/16)	Needle plate (1/16)		1	
255	M9 0911 011	W502316	丸 皿 ネ ジ 9/64(40)×7.5	Screw (for Fig. 253, 254)	2	2	
256	M9 1251 045	B 509177	ナ ッ ト 3/16(32)	Nut	1	1	
257	MQ 70A0 339	W462792	カバ ー 板 (後)	Cover plate	1		
258	MV 02A1 339	W462826	カバ ー 板 (上後)	Cover plate		1	
259	MV 02A0 339	W458129	カバ ー 板 (下)	Cover plate (lower)		1	
260	M9 0801 053	W462800	バ ネ 座 金 M8	Spring washer	6	8	
261	M9 2051 003	W502313	丸 平 ネ ジ 5/16(24)×26	Screw	6	6	
263	M9 1102 011	W500197	丸 皿 ネ ジ 11/64(40)×7	Screw (for Fig. 250)	2	2	
264	MV 01A0 325	W502314	角 駒	Square block	1	1	
265	M9 1103 045	W501528	ナ ッ ト 11/64(40)	Nut	1	1	
266	M9 0502 053	W500301	バ ネ 座 金 M5	Spring washer	1	1	
267	M9 1252 016	W502325	段 付 丸 平 ネ ジ 3/16(32)×13.3	Screw	1	1	
268	M9 1112 015	W501531	段 付 平 ネ ジ 11/64(40)×15	Screw	1	1	
269	MV 01A0 272	W452248	送 り 板	Feed plate	1	1	
270	MQ 70A0 563	W322036	直 角 台	Side cover plate bracket	1		
271	M9 1112 002	W501889	平 ネ ジ 11/64(40)×12	Screw (for Fig. 270)	4		

PB-810-10-820-10(PB-810-820)形 カマ機構部分  
 HOOK MECHANISM

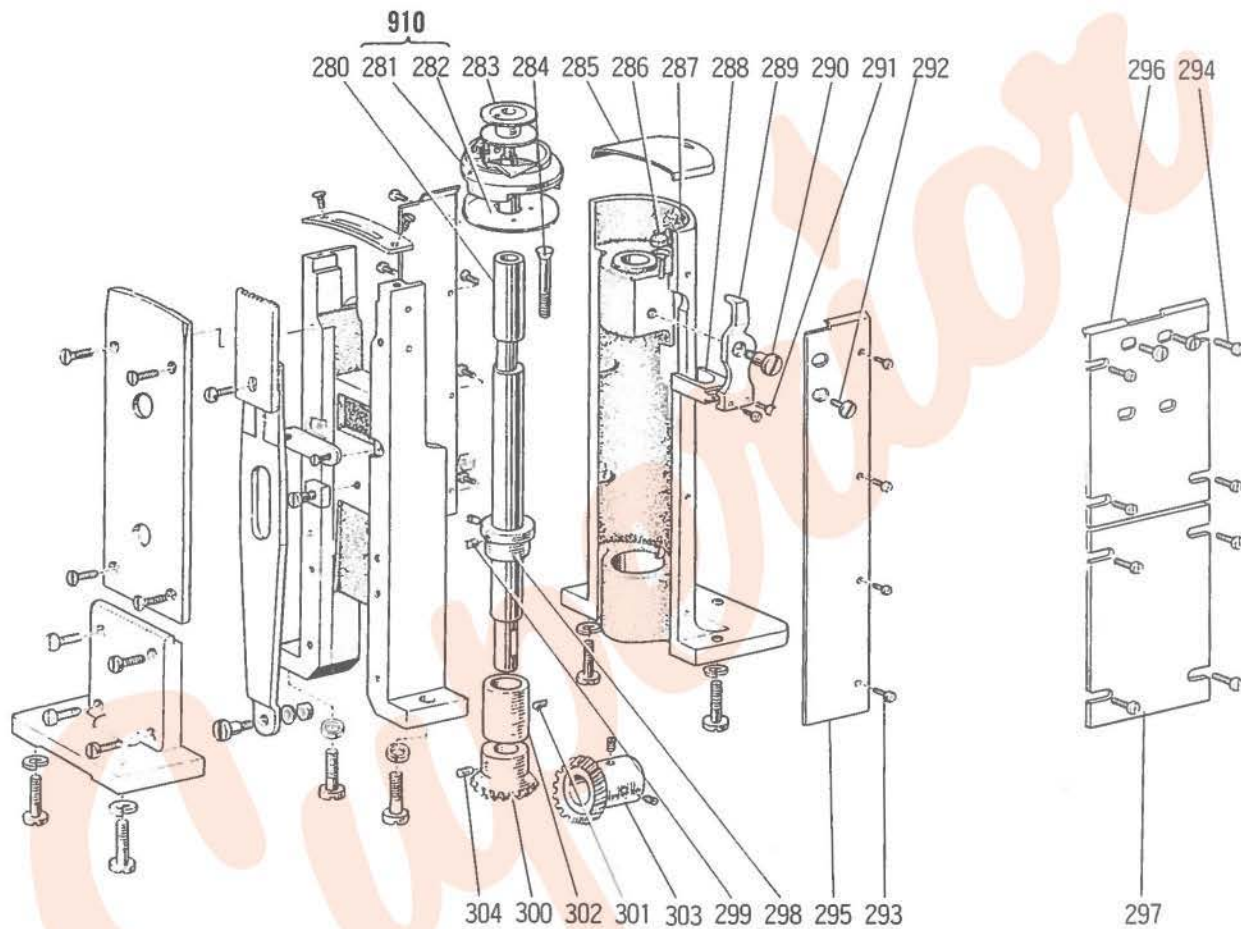

PB-810-10・820-10(PB-810・820)形 カマ機構部分  
HOOK MECHANISM

Fig. No.	サービス部品コード Part No.	資材コード Code No.	部 品 名	Name of Part	個/台 Amt. req.		備 考 Remarks
					810	820	
280	MV 01A0 355	W462892	カ マ 軸	Hook shaft	1	2	
910	MV 01A0 120	W465386	カ マ (組)	Hook Assy,	1	2	
281		W462794	カ マ	Hook	1	2	
282		W457400	針 受	Noodle bracket	1	2	
283	MF 10A0 123	W445964	ボ ビ ン	Bobbin	1	2	
284	M9 0904 010	W502318	皿 ネ ジ 9/64(40)×27	Screw (for Fig. 280)	1	2	
285	MQ 70A0 470	W456529	ス ベ リ 板	Slide plate	1	2	
286	MG 2300 740	W502203	フ ェ ル ト	Felt	1	2	
287	MV 01A0 356	W220171	カ マ 軸 台	Hook shaft supporter	1	2	
288	MV 01A0 303	W502320	オ ー プ ナ ー 台	Rotating hook opener bracket	1	2	
289	MV 01A0 300	W452252	オ ー プ ナ ー	Rotating hook opener	1	2	
290	M9 1809 015	W502319	段 付 平 ネ ジ 9/32(28)×9	Screw (for Fig. 289)	1	2	
291	M9 0912 002	W500713	平 ネ ジ 9/64(40)×8.5	Screw (for Fig. 289)	2	4	
292	M9 1113 003	W501866	丸 平 ネ ジ 11/64(40)×4	Screw	1	2	
293	M9 0903 010	W500697	皿 ネ ジ 9/64(40)×6	Screw (for Fig. 295-297)	8		
294	M9 0920 003	W500463	丸 平 ネ ジ 9/64(40)×8.5	Screw (for Fig. 295-297)		16	
295	MV 01A1 339	W452249	カバ-板 (前)	Cover plate	1		
296	MV 02A2 339	W458128	カバ-板 (上前)	Cover plate		1	
297	MV 02A0 339	W458129	カバ-板 (下)	Cover plate		1	
298	MQ 70A0 352	W502332	カ マ 軸 カ ラ ー	Hook shaft collar	1	2	
299	M9 1651 001	W500996	頭ナシ止メネジ 1/4(24)×4.8	Set screw (for Fig. 298)	2	4	
300	MQ 70A0 330	W462801	傘 歯 車 (かま軸)	Bevel gear	1	2	
301	M9 1109 001	W500985	頭ナシ止メネジ 11/64(40)×6.6	Set screw (for Fig. 302)	1	2	
302	MQ 70A0 341	W452295	カ マ 軸 メ タ ル	Hook shaft bushing	1	2	
303	MQ 70A1 330	W452223	傘 歯 車 (下軸左)	Hook shaft bevel gear (lower)	1	2	
304	M9 1606 001	B 504016	頭ナシ止メネジ 1/4(40)×7	Set screw (for Fig. 303)	4	8	

PB-810-10•820-10(PB-810•820)形 給油機構部分  
OIL LUBRICATION MECHANISM

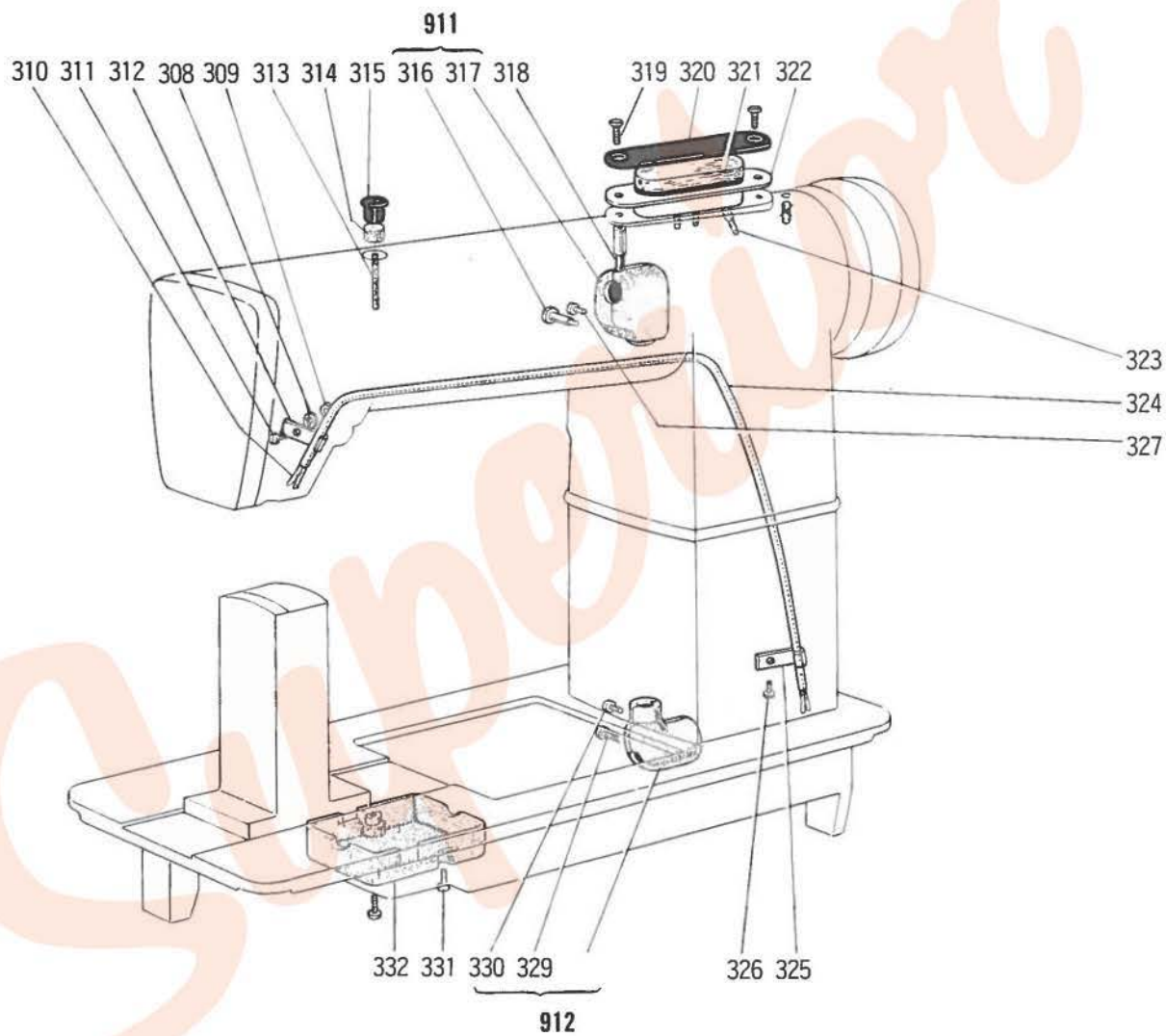

PB-810-10-820-10(PB-810-820)形 給油機構部分  
OIL LUBRICATION MECHANISM

Fig. No.	サービス部品コード Part No.	資材コード Code No.	部 品 名	Name of Part	個/台 Amt. req		備 考 Remarks
					810	820	
308	M9 0502 053	W500301H01	バネ座金 M5	Spring washer	1	1	
309	M9 1102 045	W501097H01	ナット 11/64(40)	Nut	1	1	
310	MF 10E1 148	W464047	毛糸 1.5φ×710	Woolen yarn	1	1	
311	M9 1104 002	B 509264H01	丸平ネジ 11/64(40)×12	Screw (for Fig. 312)	1	1	
312	MF 10A0 689	W444230H01	パイプホルダー	Pipe holder	1	1	
313	MF 10E2 148	W464023	油ヒモ 2.5φ×35	Oil wick	1	1	
314	MF 60A5 740	W500906	フェルト	Felt	1	1	
315	MF 60A0 133	W445617	油タンク (左)	Oil cap (left)	1	1	
911	MF 60E0 711	W464017	歯車箱(上)(組)	Gear box (upper set)	1	1	
316	M9 1851 002	W462784H01	平ネジ 9/32(20)×16	Screw (for gear box)	1	1	
318	M9 0603 060	W447199H01	ピン	Gear box (upper) pin	1	1	
319	M9 0906 011	B 509269H01	丸皿ネジ 9/64(40)×7	Screw (for Fig. 320)	2	2	
320	MF 60A0 134	W445619H01	フタ	Cover plate	1	1	
321	MF 60A4 740	W500905	フェルト	Felt	1	1	
322	MF 60A0 139	W447200	油タンク (右)	Oil tank (right)	1	1	
323	MF 10E2 148	W462984	油ヒモ 2.5φ×150	Oil wick	2	2	
324	MQ 70A0 731	W464046	ビニールパイプ	Oil pipe (vinyl)	1	1	
325	MF 60A1 689	W444233H01	パイプホルダー	Pipe holder	1	1	
326	M9 1110 002	W500294	平ネジ 11/64(40)×8	Screw (for Fig. 325)	1	1	
327	M9 1503 002	B 504000H01	平ネジ 15/64(28)×5	Screw	1	1	
912	MQ 50E0 712	W464035G01	歯車箱(下)(組)	Gear box (lower set)	1	1	
329	M9 1851 002	W462784H01	平ネジ 9/32(20)×16	Screw	1	1	
330	M9 1503 002	B 504000H-01	平ネジ 15/64(28)×5	Screw	1	1	
331	M9 1113 002	W500182	平ネジ 11/64(40)×15	Screw (for Fig. 332)	2	2	
332	MQ 70A0 710	W322736	歯車箱(かま軸)	Gear box (lower)	1	1	

PB-820-10(PB-820)形 ゲージ部分  
GAUGE PARTS



600~604



616



605



606~607



608



617~619

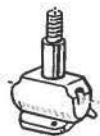

609~612

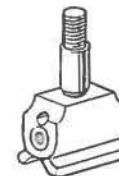

613



620~622



614



615

Supervisor

PB-820-10(PB-820)形 ゲージ部分  
GAUGE PARTS

Fig. No.	サービス部品コード Part No.	資材コード Code No.	部 品 名	Name of Part	ゲージサイズ Gauge Size						備 考 Remarks
					3 64 1/16 3/32 1/8 1/4						
					1	1.2	1.6	2.4	3.2	6.4	
600	MV 02J0 101	W458123	針 板	Needle plate	1						
601	MV 02J1 101	W458162	針 板	Needle plate		1					
602	MV 02J2 101	W45758C	針 板	Needle plate			1				
603	MV 02J3 101	W464994	針 板	Needle plate				1			
604	MV 02J4 101	W464998	針 板	Needle plate					1		
605	MV 02J8 101	W457595	針 板	Needle plate						1	
606	MV 02J0 104	W457581	送 り	Feed dog	1	1	1	1			
607	MV 02J4 104	W46520C	送 り	Feed dog					1		
608	MV 02J8 104	W45759E	送 り	Feed dog						1	
609	MV 02J0 102	W458124	針 ダ キ	Needle clamp	1	1					
610	MV 02J2 102	W45757E	針 ダ キ	Needle clamp			1				
611	MV 02J3 102	W46499E	針 ダ キ	Needle clamp				1			
612	MV 02J4 102	W465201	針 ダ キ	Needle clamp					1		
613	MV 02J8 102	W457597	針 ダ キ	Needle clamp						1	
614	MV 02J0 105	W457577	押 エ	Presser foot	1	1	1	1	1		
615	MV 02J8 105	PL-22-26-8	押 エ	Presser foot						1	
616	MV 02A0 103	W457587	針 案 内 (前)	Needle guide	1	1	1				
617	MV 02J0 103	W457578	針 案 内 (後)	Needle guide	1	1	1				
618	MV 02J3 103	W464997	針 案 内 (後)	Needle guide				1			
619	MV 02J4 103	W464999	針 案 内 (後)	Needle guide					1		
620	M9 6601 052	W465205	角 座 金 0.6t	Washer	1	1			1		
621	M9 6602 052	W465206	角 座 金 0.8t	Washer			1				
622	M9 6603 052	W465207	角 座 金 1.2t	Washer				1	1		



PB-810-10·820-10(PB-810·820)形 付 属 品  
ACCESSORIES

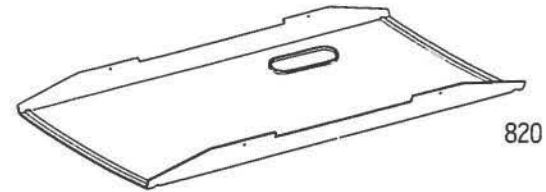
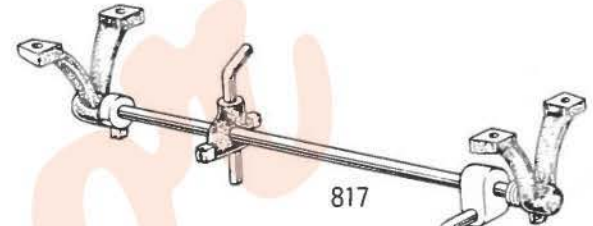
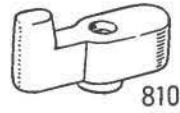
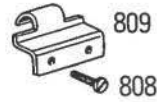
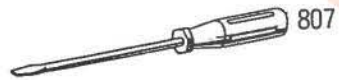
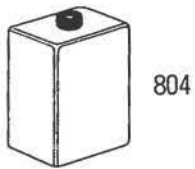
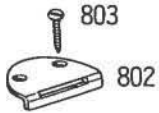
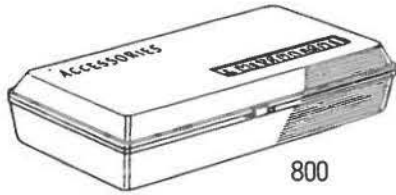

PB-810-10-820-10(PB-810-820)形 付 属 品  
ACCESSORIES

Fig. No.	サービス部品コード Part No.	資材コード Code No.	部 品 名	Name of Part	個/台 Amt. req.		備 考 Remarks
					810	820	
800	MF 60AO 749	P 833000X01	付 属 品 箱	Accessory box	1	1	
801	MF 60AO 419	W449461	防 振 ゴ ム	Vibration preventing rubbers	4	4	
802	MN 10AO 561	W445508	蝶 番 (2)	Hinge (2)	2	2	
803	M9 0501 040	W990016	皿 木 ネ ジ 5.5×25	Screw	4	4	
804	MF 60AO 137	P 831001X01	油 差 シ (大)	Oiler (large)	1	1	
805		DP×5#16	針	Needle	4	6	
806	MB 02A1 608	P 842002XC1	ネジ回シ (小)	Screw driver (small)	1	1	
807	MB 02AO 608	P 842003XC1	ネジ回シ (中)	Screw driver (middle)	1	1	
808	M9 1601 003	W466240	丸 平 ネ ジ 1/4(24)×9	Screw	4	4	
809	MN 10AO 060	W445507	蝶 番 (1)	Hinge (1)	2	2	
810	MV 01AO 778	W502740	ベ ッ ト 押 エ	Bed presser	1	1	
811	M9 0570 080	W502078	ゴ ム 栓	Rubber plug	1	1	
812	M9 0401 041	W990010	丸 木 ネ ジ 4.5×20	Screw	2	2	
813	M9 0608 050	W462776	座 金 M6	Washer	2	2	
814		W990002	釘 (8分)	Nail	8	8	
815	MN 10AO 123	W445964	ボ ビ ン	Bobbin	4	6	
816	MF 20EO 190	SM31097	糸 巻 仕 掛	Bobbin winder	1	1	
817	MV 01EO 727	SM31037	ヒ サ 上 ゲ 仕 掛	Knee lifter	1	1	
818	M9 0501 040	4.5×25	サ ラ 木 ネ ジ	Screw	1	1	
819	MF 60AO 734	W220627	ビ ニ ール カ バ ー	Vinyl cover	1	1	
820	MQ 70AO 131	W322757	油 受	Oil reservoir	1	1	
821	MF 60AO 608	W319408	ネジ回シ (大)	Screw driver (large)	1	1	

未来を開発する  
三菱電機



Superior

3

3

3

3

3